

DETMASER PRT-SERIES

WEB INSPECTION SYSTEMS FOR PAPER / BOARD INDUSTRY

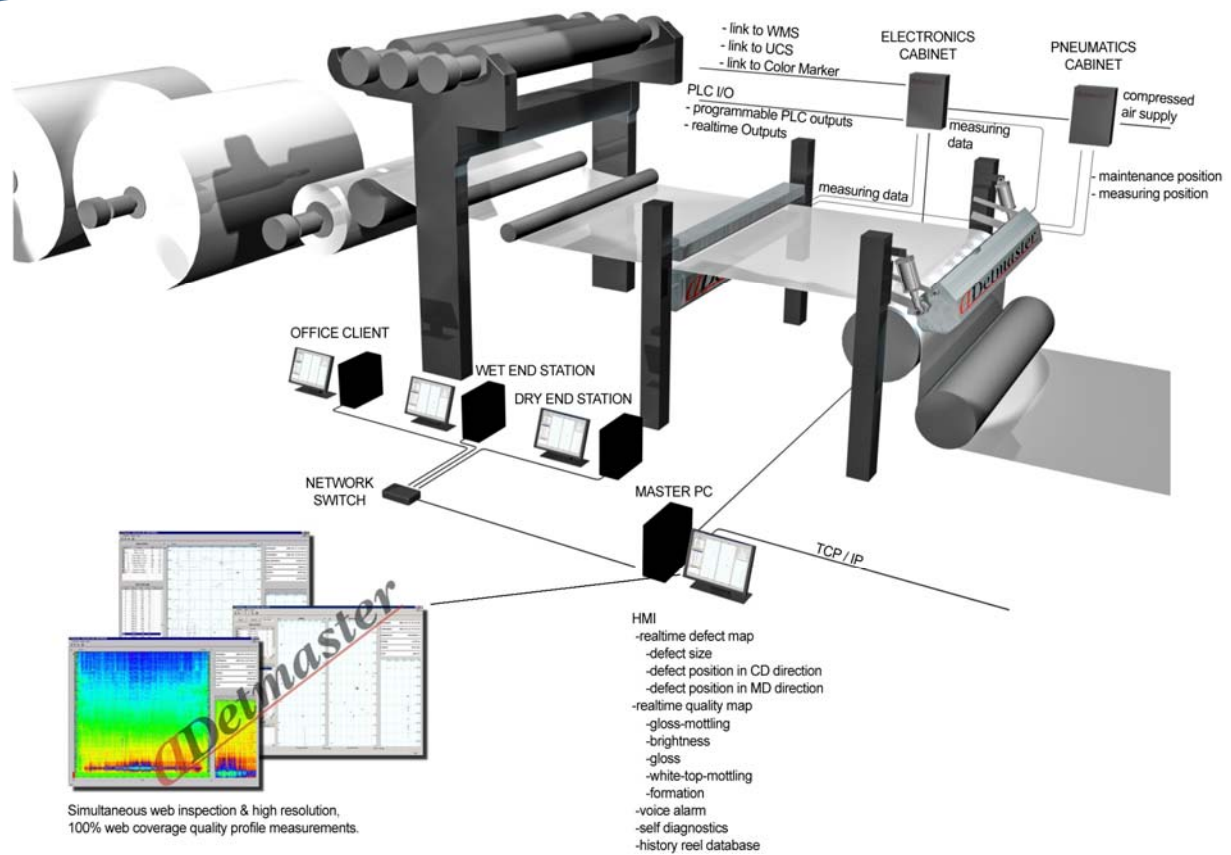

OVERVIEW

The patented Detmaster PRT - series provides brand new high performance solution for paper and board processing lines:

- Blade streak, nozzle streak, butterfly, coating skip, etc. extremely low contrast defect detection
- Hole detection even from core ply of the multi-ply board products
- Optional paper quality measurements such as gloss, brightness, gloss-mottling, formation, white top mottling, etc.
- Simple and compact system structure

Detmaster PRT system utilizes new and unique multi angle illumination technology that provides enhanced defect detection capability for paper and board applications. The system comprises efficient dark field and bright field illuminations integrated in the inspection beam as well as a separate transmission light source thanks to the multi-channel illumination method.

All Detmaster systems have been developed in close co-operation with paper and board manufacturers. As a result, superior detection and measurement accuracy, system reliability and low cost of investment and maintaining are available in just one system - Detmaster.

TECHNICAL SPECIFICATIONS

Performance	
Minimum width of detected streak:	0,1 mm
Minimum detected spot and impurity size:	1,0 mm ²
Minimum detected hole size:	0,1 – 1,0 mm ² depending on the opacity of the paper/board
Minimum detected edge crack and gore ply hole size:	5 mm ²
Applicability	
Line speed:	0 - 3000 m/min
Strip width:	No limitations
Type of measurement:	Multi-angle optical transmission and reflectance measurement
Detector Beam	
Sensors:	Multi channel detector modules with high purity silicon PIN photodiodes and DSP signal processing (DSP-processor).
Reflectance illumination:	Integrated dark field and bright field LED illumination. Illumination modes implemented by frequency division method.
Cleaning and cooling:	Automatic with low pressure air
Distance from web:	50 mm
Transmission light source	
Type:	LED array emitting modulated light
Cleaning and cooling:	Automatic with low pressure air
Mean time before failure:	8 years
Distance from web:	100 mm
Power supply	
Power consumption:	200 W/m, voltage 110 – 240 VAC, 43 – 60 Hz
User Interface	
Hardware:	PC, 22" LCD Color Display, Mouse + Keyboard
Software:	Windows based including defect maps, defect type and location listings, trends, historic data, self-diagnostics, alarms, user defined threshold levels
Mill interface	
Isolated digital outputs:	10 user definable
Isolated digital inputs:	8
Mill way connection:	TCP/IP (optional)
Analog output:	4 CH 0 – 10 VDC / 4 – 20 mA (optional)
Dimensions	
Space requirements:	MD: 500 mm, above web 650 mm, below web 300 mm for single-side installation MD: 500 mm, above web 650 mm, below web 650 mm for double-side installation
Electronics cabinet:	H 1000 mm, W 600 mm, L 250 mm
Standard Operating Environment	
Operating temperature:	+10 °C - +50 °C
Humidity:	30...90%, non-condensing
Options available	
Various types of integrated optical paper quality measurements:	E.g. gloss-mottling, brightness, gloss, formation, white top mottling.
<p>The data listed herein falls within the normal range of product properties but they should not be used to establish specification limits or used alone as the basis of design. Because SR-Instruments cannot anticipate or control the many different conditions under which this information and/or product may be used, it does not guarantee the applicability or the accuracy of this information or the suitability of its products in any given situation. Users of SR-Instruments' products should make their own tests to determine the suitability of each such product series for their particular purposes. Product samples are tested at SR-Instruments application center free of charge. For product sample testing, please contact our sales (sales@sr-instruments.com) or refer to document no WI47000 ("Sending samples to be tested").</p>	